

Product Specification Sheet



OPERA-GH JACKSHAFT OPERATOR

STANDARD FEATURES

- **Motor:**
60Hz high starting torque, continuous-duty, single phase capacitor start or 3 phase motor, open drip proof with enclosed ends or drip cover, protected against overload. Also available with 50Hz 220V 1 phase and 380V 3 phase motor, consult inside sales.
- **Reduction:**
45:1 worm gear in oil bath reducer with air breather and sealed ball bearings. Output shaft is 1" with 1/4" keyway up to 1HP, 1-1/4" output shaft with 1/4" keyway above 1HP. Output shaft speed: 38 rpm.
- **Drive:**
#50 roller chain with a 50B12 sprocket for the operator drive shaft. Door sprocket selected for a door travel of 6"/s to 12"/s.
- **Brake:**
Electrically activated drum-band type solenoid brake.
- **Manual Operation:**
Hoist-a-matic® self-engaging hoist (floor level engagement device is not required to operate), for manual chain operation. An electrical interlock automatically disconnects power to the motor operator when chain hoist is engaged. Hoist on right is standard, but it can be easily moved to the left in the field.
- **Electrical Enclosure:**
All electrical components are in a Nema 1 enclosure. Hinged electrical enclosure cover.
- **Limit System:**
Rotary-type oil-impregnated steel cams, commercial grade switches. Limit shaft is supported by self-lubricating bronze bushings for increased precision. Remains in time when there is a manual operation or after the motor has been removed.
- **Accu-cam® Feature:**
Precise and quick one-handed adjustment of the limits.
- **Corrosion Protection:**
Reducer, control enclosure and frames protected by baked on, long lasting enamel finish. Polymer control box cover. Limit and hoist shafts protected by yellow chromate coating.
- **Mounting:**
Wall mounted, vertical front of hood mounted or horizontal top of hood mounted, on the right or the left of the door. The use of a wall mounting bracket is recommended.
- **Shipping Weight:**
Approx. 122 Lbs - 55 Kg.
- **Warranty:**
2 Years.

Hoist-a-matic®

Self-engaging chain hoist with automatic cut-off

Accu-cam® Limit Feature

For precise and quick one-hand limit setting adjustments

Hinged Cover With Stable Opened Position

For easy access to components and wiring



The Opera-GH is a heavy-duty worm gear industrial operator designed for use on industrial standard, high and vertical lift sectional doors or rolling doors and grilles.

The operator can be wall, hood, or shelf mounted on either side of the door. It incorporates the patented Hoist-a-matic®, a self-engaging chain hoist for manual operation, which simplifies operation and installation.

The operator is available with the new Electronic Control Board (BOARD 070) with or without the option of electrical control for MONITORED external entrapment protection devices (UL325-2010 compliant).



When you think
Commercial Door OPERATORS,
just think OPERA.

800-361-2260
info@manaras.com
www.manaras.com

CONTROL OPTIONS

• ECB Units (BOARD 070):

24Vdc relaying circuit with a 40VA class II transformer, non-volatile memory. Features available: 1.5s delay on reverse, programmable maximum run timer, mid-stop, timer to close (suspension possible from floor level), independent input loop terminal, advance close system, test buttons, reverse wiring detection and door lock sensor. Operating mode selectable on site: C2, B2, D1, E2, T or TS.

• "M" Version:

Provides the monitoring of Primary External Entrapment Protection Devices. Includes monitored photo cells (PHOTO 062 standard). In this mode, Ancillary Entrapment Protection Devices (optional) may be used to supplement primary entrapment protection, such as non-monitored photo cells, 2-wire non-monitored sensing edges and pneumatic sensing edges. Certifications: CSA C22.2-247.92 and UL325 5th Ed. PRIOR to August 2010 revision.

• "E" Version:

No monitoring function. Certifications: CSA C22.2-247.92 and UL325 5th Ed. PRIOR to August 2010 revision.

• Contactor Units:

24VAC control circuit, 40VA class II transformer, fuse protected on output, heavy-duty across-the-line linear reversing contactor with mechanical interlock.

• B2/C2 Units:

C2 wiring is standard. B2 can be set very easily by moving one wire. Available options: delay on reverse, timer to close, double limits, etc... Certifications: CSA C22.2-247.92 and UL325 5th Ed. PRIOR to August 2010 revision.

Note: CSA C22.2-247.92 and UL325 apply to units intended to be used in ordinary locations in accordance with the Canadian Electrical Code, Part I and the National Electrical Code, NFPA 70, respectively.

MAIN OPTIONS

• Control Accessories:

Angled terminal strip allows for the connection of 3-button stations (one supplied with the operator), non-monitored sensing edges, non-monitored photo cells, one push-button radio control (external strip), ceiling pull switches, key switches, loop detectors, external interlocks, plug-in radio card and universal auxiliary output module. 2A fuse protected 24VAC output is available for accessory power supply. NEMA 4/12 or NEMA 4X protected monitored photo cells upgrade available.

• Environmental Modifications:

Former GH model available. NEMA 4/12, NEMA 4X and NEMA 7/9 enclosures, consult inside sales.

• Friction Clutch (Optional):

Easily adjustable slip clutch, ideally positioned on output shaft. Recommended for sectional doors.

• Mechanical Accessories:

Wall or hood mounting bracket, chain spreader, hand crank, etc...consult inside sales.

• Mechanical Modifications:

Left hand chain hoist, #60 roller chain, sprocket on final drive, limit shaft speed-up, etc... consult inside sales.

DIMENSIONS

Clearance: Side room required 15" (380 mm)
With friction clutch add: 1.5" (38 mm)

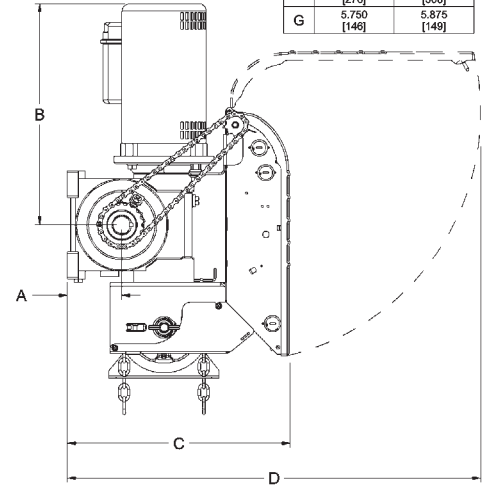
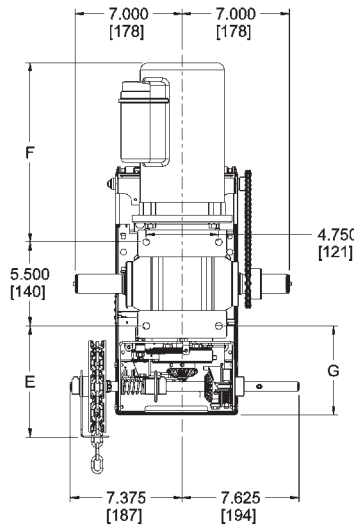

	UP TO 1 HP	1.5 & 2 HP
A	3.000 [76]	3.500 [89]
B	13.625 MAX. [346]	14.625 MAX. [371]
C	14.000 [356]	14.625 [371]
D	26.500 [673]	27.125 [689]
E	7.250 [184]	7.375 [187]
F	10.875 MAX. [276]	12.125 MAX. [308]
G	5.750 [146]	5.875 [149]

MOTOR SELECTION

Maximum Size of Door in Square Feet

Horse Power	Rolling Doors					Sectional Doors				
	Insulated Steel	16 ga. Steel	Steel Grilles 20 ga. Steel	Alu. Door 22 ga. Steel	Alu. Grilles 24 ga. Steel	Steel 18 ga. Ins.	Steel 18 ga. 20 ga. Ins.	Wood Steel 20 ga. 22 & 24 ga. Ins.	Aluminum Steel 22 & 24 ga.	Fiber Glass
1/2	157	236	260	319	358	196	245	314	343	392
3/4	206	294	358	451	515	270	319	441	490	549
1	255	358	446	574	613	294	392	490	564	613
1-1/2	353	486	633	-	-	373	466	549	613	-
2	451	613	-	-	-	-	-	-	-	-

General Guideline

OPERATOR RANGE

Current Consumption (Amp.)

Horse Power	120V 1 Ph	240V 1Ph	208/240V 3 Ph	480V 3 Ph	600V 3 Ph
1/2	8.6	4.1	2.2	1.1	-
3/4	10.4	5.2	2.8	1.4	1.1
1	13.4	6.7	3.4	1.7	1.4
1-1/2	18.6	9.3	4.8	2.4	1.9
2	-	-	6.2	3.1	2.5

General Guideline

